

CUSTOMER SERVICES CONTACT

COUNTRIES / REGIONS	SERVICE CENTER LOCATIONS
United Kingdom	<p>Telephone: 01702208172</p> <p>Address: Geemac sales & Marketing Limited 12 Eldon Way Hockley Essex SS5 4AD</p>
France	<p>Telephone: 33(0) 9 69 360535</p>
Spain	<p>Telephone: 0902848775</p>
Italy	<p>Telephone: 0800788298</p> <p>Address: 12 Eldon Way Hockley Essex</p>
Germany	<p>Telephone: 0621 8455 210</p> <p>Address: Germany Sales & Service Office RMS GmbH Besselstr.25, 68219 Mannheim Service@rms-gruppe.de</p>
Australia and Islands	<p>Telephone: 1800-451-190</p>
<p>For answers to most frequently asked questions, please visit https://polygroup.zendesk.com/hc/en-us</p>	

**SUMMER WAVES™
CARTRIDGE FILTER PUMP**

FOR ABOVE GROUND SWIMMING POOLS
RX600-NF & RX1000-NF & RX1500-NF models

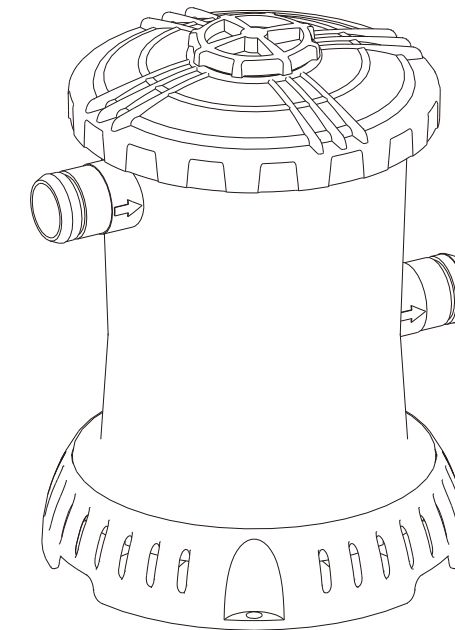

PGIM_CartridgeFilterPumpRX600-1000-1500-NF_EU_201512_V01

READ, AND KEEP THESE INSTRUCTIONS FOR FUTURE REFERENCE

Should you encounter a problem with your Polygroup® Product, please do not return the product to the place of purchase. All Warranty claims must be made directly to Polygroup®. Prior to contacting Customer Service, please first review the Troubleshooting Guide in the Installation Manual, or review the FAQ at www.Polygroup.com. Please review setup instruction videos on www.Polygroup.com/video. If you are still unable to correct the problem, please contact Polygroup® Customer Service at Appendix . Have the product type and your purchase receipt ready. Our Customer Service Representative will assist you in resolving the problem. You may be asked to return all or part of the product for inspection and/or repair. Do not return any product to Polygroup® without a Return Authorization number.

LIMITED WARRANTY

Polygroup® Limited (Macao Commercial Offshore), (hereinafter "Polygroup®") warrants to the original purchaser only, the RX type Electric Filter Pump against defects in material and workmanship for 180 days from the date of purchase. Original Purchaser must retain proof of such purchase in the form of an original store sales receipt and must produce such upon request by Polygroup® or its designated agents. Warranty claims cannot be processed without a valid proof of purchase. This Limited Warranty applies only to the original purchaser of the product and is limited solely to the repair or replacement of the product, to be decided in Polygroup®'s sole discretion. Consequential damages, including claims for loss of water, pool chemicals, damage, or labor are not covered under this Limited Warranty.

This Warranty will be declared invalid should the Purchaser modify or repair the product themselves or by unauthorized persons; use non-Polygroup® parts or accessories with the product; use the product in contravention of the manufacturer's Instructions; use improper voltage; abuse the product in any way; or through accident or negligence. Normal wear-and-tear is not covered under this Warranty, nor are acts of God outside the control of Polygroup®.

IN NO EVENT SHALL Polygroup®, THEIR AUTHORIZED AGENTS, RELATED ENTITIES, OR EMPLOYEES BE LIABLE TO THE BUYER OR ANY OTHER PARTY FOR DIRECT OR CONSEQUENTIAL DAMAGES. Some states or countries, or others jurisdictions do not allow the exclusion or limitation of incidental or consequential damages, so the above limitation or exclusion may not apply to you.

TABLE OF CONTENTS

Warnings	3 ~ 6
Save These Instructions & Filter Pump Power Information & Parts List	7 ~ 9
Setup Instructions	10 ~ 11
Filter Pump Operation & Motor Protection & Filter Cartridge Cleaning and Replacement	12
Pump Maintenance & Water Care.....	13
TroubleShooting Guide & Pump Disassembly and Storage	14
Rotor Replacement Instructions	15 ~ 16
Replacement Part Ordering Information & Pool Storage & Winterizing.....	17
Customer Services Contact	18

IMPORTANT SAFETY INSTRUCTIONS

When installing and using this electrical equipment, basic safety precautions should always be followed, including the following:

READ AND FOLLOW ALL INSTRUCTIONS

Keep for Future Reference. Failure to follow these warnings and instructions can result in serious injury or death to users, especially children.

⚠ DANGER		⚠ WARNING	
PREVENT DROWNING	NO DIVING! NO JUMPING!	DO NOT SIT ON OR LAY OVER POOL WALL	AVOID ENTRAPMENT
Watch children at all times. Observe all Safety Rules.	Shallow Water - You can be permanently injured.	You can be permanently injured.	Stay away from suction fittings. You may drown.

NOTICE: CUSTOMERS THAT PURCHASE POOLS MAY BE REQUIRED BY LOCAL OR STATE LAW TO INCUR ADDITIONAL EXPENSES WHEN INSTALLING A POOL, IN ORDER TO COMPLY WITH STATE OR LOCAL LAWS REGARDING FENCING AND OTHER SAFETY REQUIREMENTS. CUSTOMERS SHOULD CONTACT THEIR LOCAL BUILDING CODE ENFORCEMENT OFFICE FOR FURTHER DETAILS.



Please read carefully and keep for future reference

⚠ WARNING

Safety Care for Children

The safety of your children is your own responsibility

1. Children, especially children younger than five years, are at high risk of drowning.
2. Keep children in your direct sight, stay close, and actively supervise them when they are in or near this pool and when you are filling and emptying this pool.
3. When searching for a missing child, check the pool first, even if the child is thought to be in the house.
4. Locate pumps and filters in such a way that children cannot climb on them and gain access to the pool.
5. **WARNING:** To reduce the risk of injury, do not permit children to use this product unless they are closely supervised at all times.
6. Do not allow children who cannot swim into the water without a life jacket or vest or when unaccompanied.
7. Designate one person to take responsibility for safety.
8. Be extra vigilant when several people are using the pool at the same time.
9. Teach your children to swim as soon as possible.
10. Store water treatment products out of the reach of children.

Swimming Pool Barriers

Very Important: Swimming pool barriers, which restrict access to the pool by small children, may be required by law. A barrier is necessary to provide protection against potential drowning and near drowning. Barriers are not a substitute for constant supervision of children. Check state or local laws and codes before setting up pool.

Swimming Pool Equipment

1. Keep all electrical lines, radios, speakers, and other electrical appliances away from the pool.
2. Do not place pool near or under overhead electrical lines.

Filter Pump Awareness

1. **WARNING!** Following the pool manufacturer's instructions and install your pool properly before installing this filter pump.
2. **WARNING!** Adult assembly required.
3. **WARNING!** Before starting, check all pipes and accessories for correct installation and reliable connection.
4. **WARNING!** Do not bury the electric cords. Place the cords where lawn mowers, hedge trimmers and other equipment will not damage them.
5. **WARNING!** Do not use an extension cord to connect unit to electric supply.
6. **WARNING!** Prevent children from using the filter pump without an adult's supervision.
7. **WARNING!** Do not use the filter pump when pool is empty. This pump is designed only for dismountable above ground pools, not for permanently

installed pools. Improper use may lead to overheating and permanent damage of the product.

8. **WARNING!** To avoid the risk of electric shock, always be aware of damaged cords.
9. **WARNING!** The power cord cannot be replaced. If the cord is damaged, the the filter pump should be disposed of.
10. **WARNING!** To avoid the risk of electric shock, connect the filter pump only to a receptacle protected by Residual-current device (RCD). The pump must be supplied through residual current device (RCD) having a rated residual operating current not exceeding 30 mA. Contact a qualified electrician if you cannot verify that the receptacle is RCD protected. Use a qualified electrician to install the RCD.
11. **WARNING!** This appliance can be used by children aged from 8 years and above and persons with reduced physical, sensory or mental capabilities or lack of experience and knowledge if they have been given supervision or instruction concerning use of the appliance in a safe way and understand the hazards involved. Children shall not play with the appliance. Cleaning and user maintenance shall not be made by children without supervision.
12. **WARNING!** Children should be supervised to ensure that they do not play with the appliance.
13. **WARNING!** Filter system can be used as many hours as desired, but NEVER when the pool is occupied.
14. **WARNING!** Pollution of the liquid could occur due to leakage of lubricants.
15. **CAUTION:** This pump is for use with storable pools only. Do not use with permanently-installed pools. A storable pool is constructed so that it is capable of being readily disassembled for storage and reassembled to its original integrity. A permanently-installed pool is constructed in or on the ground or in a building such that it cannot be readily disassembled for storage.
16. **CAUTION:** For continued protection against possible electric shock this unit is to be mounted to the base in accordance with the installation instructions.
17. The Filter Pump is to be assembled by an adult; care should be taken in the unpacking and assembly of the Filter Pump, this pool may contain accessible potentially hazardous sharp edges or sharp points that are a necessary part of the function of the Filter Pump.
18. If a drain or suction outlet cover is missing or broken, do not use the pool. Suction can cause body part entrapment, hair and jewelry entanglement, evisceration, or drowning. Repair or replace the drain or suction outlet cover before allowing the pool to be used. During nighttime pool use, artificial lighting shall be used to illuminate all safety signs, ladders, steps, deck surfaces, and walks.
19. The floor of the pool shall be visible at all times from the outside perimeter of the pool.
20. Post a list of emergency telephone numbers such as the nearest available police, fire, ambulance, and/or rescue unit. These numbers are to be kept near the telephone, which is closest to the pool and ladder.
21. Basic lifesaving equipment, including one of the following should be on hand at all times:
 - A light, strong, rigid pole (shepherds crook) not less than twelve feet (12') [366cm] long.
 - A minimum one-fourth inch (1/4") [6.35 mm] diameter rope as long as one and one half (1-1/2) times the maximum width of the pool or fifty feet (50') [15.24 meters], whichever is less, which has been firmly attached to a Coast Guard-approved ring buoy having an outside diameter of approximately fifteen inches (15") [38.1 cm], or similarly approved flotation device.
22. Warning. Only for domestic use.
23. Children can drown in very small amounts of water. Empty the pool when not in use.
24. Do not install the paddling pool over concrete, asphalt or any other hard surface.
25. Place the product on a level surface at least 2 m from any structure or obstruction such as a fence, garage, house, overhanging branches, laundry lines or electrical wires.
26. The product must be assembled/disassembled by adult.
27. A weekly check is recommended for backwashing or cleaning.
28. It is essential to check that the suction openings are not obstructed.
29. It is advisable to stop the filtration during maintenance operations on the filtration system.
30. Regularly monitor the filter clogging level.
31. It is essential to change any damaged element or set of elements as soon as possible. Use only parts approved by the person responsible for placing the product on the market.
32. **DO NOT** overfill the pool and/or allow anyone to lie over or lean on the inflated ring. This will cause the wall of the pool to collapse! Drain the pool to the correct water level after heavy rain.
33. **NOTE:** DO NOT attempt to assemble this pool when the temperature is below 16°C.
34. **NOTE:** This pool can be disassembled and stored away, a procedure which should be carried out when temperatures are expected to fall below 4°C.
35. **NOTE:** DO NOT use the pump when people are in the pool.
36. **DO NOT CONCEAL THE CORD:** Locate the cord away from lawn mowers, brushcutters and other garden equipment.
37. **CAUTION:** To reduce the risk of electrocution, do not use extension cords to connect the device to the mains supply; provide a suitably located outlet.
38. **IMPORTANT NOTE:** If you do not use the pump with an electric power supply, you risk damaging the pump or causing an accident.
39. **DO NOT REMOVE THE EARTH PIN, DO NOT MODIFY THE PLUG, DO NOT USE AN ADAPTER:** Contact a qualified electrician for any problems associated with the earthing of your plugs.
40. Handle the pump with care. Avoid dragging or carrying the pump by its electric cord. Never remove the plug by pulling on the electric cord. The electric cord must be intact. Never expose the pump filter to sharp objects, oil, moving parts or heat.
41. **NOTE:** Place the pump on a secure, level base. Check that the location of the pool and the pump are sufficiently ventilated, that the water can be drained correctly and that there is sufficient access for cleaning. Never place the pump in a location where water may gather or a high volume of people pass through. The pump must be positioned at least two metres from the pool.
42. The pump's power plug must be located at least 3.5 metres from the pool.
43. After installing the pool, the plug must be easily accessible.
44. **NOTE:** The weather may compromise the performance and lifespan of your filter pump. If it is exposed to cold, direct sunlight, or heat, it may become unusable so you should protect it from the elements if possible. Before carrying out any maintenance or disassembly of the pump, do not forget to replace the waste filters with the blue inlet and outlet nozzle protectors fitted at the factory.
45. **NOTE:** Do not operate the device for more than 15 hours per day.
46. **NOTE:** Do not add any chemical products to the filter pump.
47. It is essential to check that the inlet holes are not blocked.
48. It is recommended that filtration is stopped while maintenance work is being carried out on the filter system.
49. Do not allow the pool to be used if the filter system(s) is/are damaged.
50. It is essential to change any damaged part or parts as soon as possible. Only use parts approved by the marketing authorisation holder.

51. Make sure that people who cannot swim use personal flotation devices.
52. Do not allow races or similar active games to take place around the pool.
53. Do not leave toys near or in the pool when unsupervised.
54. An electronic perimeter or immersion detector which is enabled and functioning. Please note that these devices are in no way intended to act as a substitute for close supervision.
55. **NOTE:** The maximum total dynamic head is as following.

Model	RX600-NF	RX1000-NF	RX1500-NF
Total head	2m	3.6m	3.7m

Circulation Systems

1. Installers shall follow written instructions regarding positioning of all equipment connected to the circulation systems.
2. The installer shall follow written instructions provided for operating the circulation system components.
3. All circulation system components and pump that require replacement or servicing shall be installed according to the pump's instruction manual.
4. Circulation equipment shall be installed per manufacturer's instructions to provide proper mounting and support, to prevent damage from misalignment, settlement, and vibration, and to minimize the potential for the accumulation of debris and moisture. Please refer to pump's instruction manual.

Chemicals

For safety sake, ensure the deepest part of the pool is always visible. The user must properly maintain clarity of the pool water at all time. Check the pH and chlorine levels periodically, and make sure they are within the recommended limits. Additional water treatment chemicals might be needed from time to time. Have the water sample tested by a local pool supply store to determine if additional chemical is needed. Turn on the filter pump system for at least six hours per day. Clean and replace filter cartridge frequently. Replace only with genuine Polygroup® / Summer Wave™ Brand filter cartridge. Refer to the Filter Pump manual for additional water care information.

Entrapment Risk

1. **Entrapment Avoidance:** There shall be no protrusions or other obstruction in the swimming area, which may cause entrapment or entanglement of the user. If a suction outlet cover is missing or broken, do not use the pool. Suction can cause body part entrapment, hair and jewelry entanglement, evisceration, or drowning. Repair or replace the suction outlet cover before allowing the pool to be used.
2. **DANGER! TO AVOID SERIOUS INJURY OR DEATH, CLOSE THE POOL OR SPA TO BATHERS IF ANY SUCTION OUTLET COVER/GRATE IS MISSING, BROKEN, OR INOPERATIVE.**
3. Never play or swim near drains or suction fittings. Your body or hair may be trapped causing permanent injury or drowning.
4. Never enter the pool or spa if a suction fitting or drain cover is loose, broken, or missing.
5. Immediately notify the pool/spa owner or operator if you find a drain cover loose, broken, or missing.

Drowning Risk

1. Keep unsupervised children from accessing the pool by installing fencing or other approved barriers around all sides of pool. State or local laws or codes may require fencing or other approved barriers. Check state or local laws and codes before setting up pool.
2. Toys, chairs, tables, or similar objects that a young child could climb shall be at least four feet (4') [121.92 cm] from the pool. The pump filter system shall be positioned so as to prevent it being used as a means of access to the pool by young children. Do not leave toys inside pool when finished using, since toys and similar items might attract a child to the pool.
3. Position furniture (for example: tables, chairs) away from pool and so that children cannot climb on it to gain access to the pool.

Electrocution Risk

1. Keep all electrical lines, radios, speakers, and other electrical appliances away from the pool.
2. Do not place pool near or under overhead electrical lines.

First Aid

1. Keep a working phone and a list of emergency numbers near the pool.
2. Become certified in cardiopulmonary resuscitation (CPR). In the event of an emergency, immediate use of CPR can make a lifesaving difference.
3. In the event of an accident:
 - Get the person out of the water as quickly as possible;
 - Immediately call the emergency services and follow the advice you are given;
 - Remove any wet clothing and wrap the person in a warm blanket.

Special Warning

1. Local building codes may require obtaining a building or electrical permit. Installer shall follow regulations on setback, barriers, devices, and other conditions.
2. **DO NOT** attempt to assemble this pool in adverse weather conditions, windy conditions, or when the temperature is below 60°F.
3. This is a storable filter pump, which should be disassembled and stored when temperatures are expected to fall below 32°F.

Extra Safety Warning

1. Adult supervision is always required.
2. Parents should learn CPR.
3. Keep all electrical radios, speakers, and other appliances away from the swimming pool.
4. When you touch the filter, pump, or electrical parts, be sure the ground under your feet is "Bone Dry."
5. Connect power cords to a 3-wire grounding-type outlet only.
6. Keep all breakable objects out of the pool area.
7. Alcohol consumption and pool activities do not mix. Never allow anyone to swim, dive, or slide under the influence of alcohol or drugs.

8. Severe electrical shock could result if you install your pump or filter on a deck. The pump or filter could fall into the water, causing severe shock or electrocution.
9. Do not install on a deck or other surface at, above, or slightly below the top rail of the pool.
10. Do not use the filter pump during severe weather conditions, i.e. electrical storms, tornadoes, etc.
11. Be aware of overhead power lines when vacuuming your pool or using a telescoping pole.
12. Check regularly for signs of wear or loose bolts that could make the deck unsafe.
13. Please contact pool site dealer or manufacturer for additional safety signs if deemed necessary.
14. For pool service, select a certified pool professional.
15. Learn life-saving techniques, in particular those which can be used on children.
16. The weather may compromise the performance and lifespan of your filter. If it is exposed to cold, direct sunlight, or heat, it may become unusable so you should protect it from the elements if possible.

ANY MAINTENANCE WORK TO AVOID RISK OF SERIOUS INJURY OR EVEN DEATH.

15. GENERAL INFORMATION: The pool must be stored away if temperature is expected to fall below 4°C.
16. All parts should be cleaned using mild soap and lukewarm water only. DO NOT use detergent or hot water.
17. Make sure that all parts are dry before storing them to prevent mildew from forming.
18. Store all parts in a dry, heated location where temperature does not fall below 4°C or exceed 51°C.
19. Failure to follow the storage instructions could cause damage to your pool and void your warranty.
20. YOU MUST FOLLOW THE ASSEMBLY INSTRUCTIONS TO REASSEMBLE YOUR POOL FOR THE NEXT SEASON.
21. The site for the pool must be cleared and leveled.
22. Do not leave an above-ground pool outside when empty.

Installation recommendation

1. Filter can be permanently accessible and check the type of the filter media (Type A/C or D) on filter packaging.
2. A weekly check is recommended for backwashing or cleaning.
3. It is essential to check that the suction openings are not obstructed.
4. It is advisable to stop the filtration during maintenance operations on the filtration system.
5. Regularly monitor the filter clogging level.
6. Minimum daily filtration operating time is 8 hours.



Processing of electric and electronic equipment at the end of their service life (applicable in member countries of the European Union and other European countries operating a selective waste collection system).

This symbol, affixed to the product or its packaging, indicates that the product must not be processed with household waste. It must be brought to an electric and electronic waste collection point for recycling and disposal. By ensuring the appropriate disposal of this product you also help in preventing potentially negative consequences for the environment and human health. The recycling of materials helps preserve our natural resources. For further information regarding the recycling of this product, please contact your municipality, local waste disposal centre or the store where the product was purchased.

Electrical product waste should not be discarded with household waste, use separate collection facilities.

Contact your local government or council for information regarding the collection systems available.

Maximum Water Temperature: 35 degree

SAVE THESE INSTRUCTIONS

Preliminary Steps:

1. READ ALL INSTRUCTIONS CAREFULLY and get a thorough understanding of what is required to assemble your RX series Filter Pump.
2. Before you begin to assemble the pool, identify, count, and check all parts needed for assembly.
3. It is recommended that you have some PETROLEUM JELLY on hand for lubricating the gaskets.

Filter Pump Important Notes:

1. Installer shall follow written instructions provided for operation of the filter pump systems.
2. The Type D Filter Cartridge **16** will hold as many as 2 of the 1" diameter chlorine tablets and the Type A/C Filter Cartridge **16** will hold as many as 6 of the 1" diameter chlorine tablets. Check your chlorine levels to determine the proper number of chlorine tablets to add. The filter cartridge will automatically dispense chlorine into the pool as the Filter Pump runs. You must have the type of Filter Cartridge **16** with a central core mesh divider (See page 9) to use the chlorine dispenser. DO NOT use this to dispense powdered chlorine, shock treatment, or any other type of chemicals as damage to the pump, filter cartridge, and pool will occur.
3. The RX Series Filter Pump systems are manufactured by Polygroup® and ETL control number 4000608 and 4006317 - double insulated and grounded - 220-240 V.A.C - 50Hz.
4. The RX TYPE filter pump must be powered by a minimum of 210 V in order to start and operate correctly.
5. In addition to the parts provided with your pool, you will also need a SCREWDRIVER to assemble your pool.
6. If working on the electrical circuit, disconnect it and lock the fuse box door. If working on the electric circuit, disconnect it and lock the fuse box. If not, you run the risk of electrocution, serious injury or even death.

FILTER PUMP POWER INFORMATION

Model	Voltage	AMPERAGE	Wattage (W)	Water Proof Level
RX600-NF	Input voltage 220-240V	0.5 Amps	65 Watts	IPX7
RX1000-NF	Input voltage 220-240V	0.6 Amps	90 Watts	IPX7
RX1500-NF	Input voltage 220-240V	1.5 Amps	190 Watts	IPX7

PARTS LIST

ITEMS	PARTS NAME	QTY.	ITEMS	PARTS NAME	QTY.
1	Suction Fitting Base	2	11	Base	1
2	Suction Fitting Screen	1	12	Canister Gasket	2
3	Flow Diverter	1	13	Filter Pump Canister	1
4	Plug	2	14	Nozzle	1
5	Hose	2	15	Motor Assembly	1
6	Hose Camp	4	16	Type D Filter Cartridge (RX600 only)	1
				Type A/C Filter Cartridge (RX1000 & RX1500)	
7	Filter Pump Assembly	1	17	Stator	1
	A) RX600		18	Rotor Assembly	1
	B) RX1000		19	Volute Cover	1
	C) RX1500				
8	Vent Screw	1	20	Volute Cover Lock Nut (RX600 & RX1000)	1
9	Vent Screw O-Ring	1	21	Volute Cover Bolt and Nut Set (RX1500 only)	1 set
10	Seal Top	1	22	Filter Pump Port / Fitting O-Ring	2

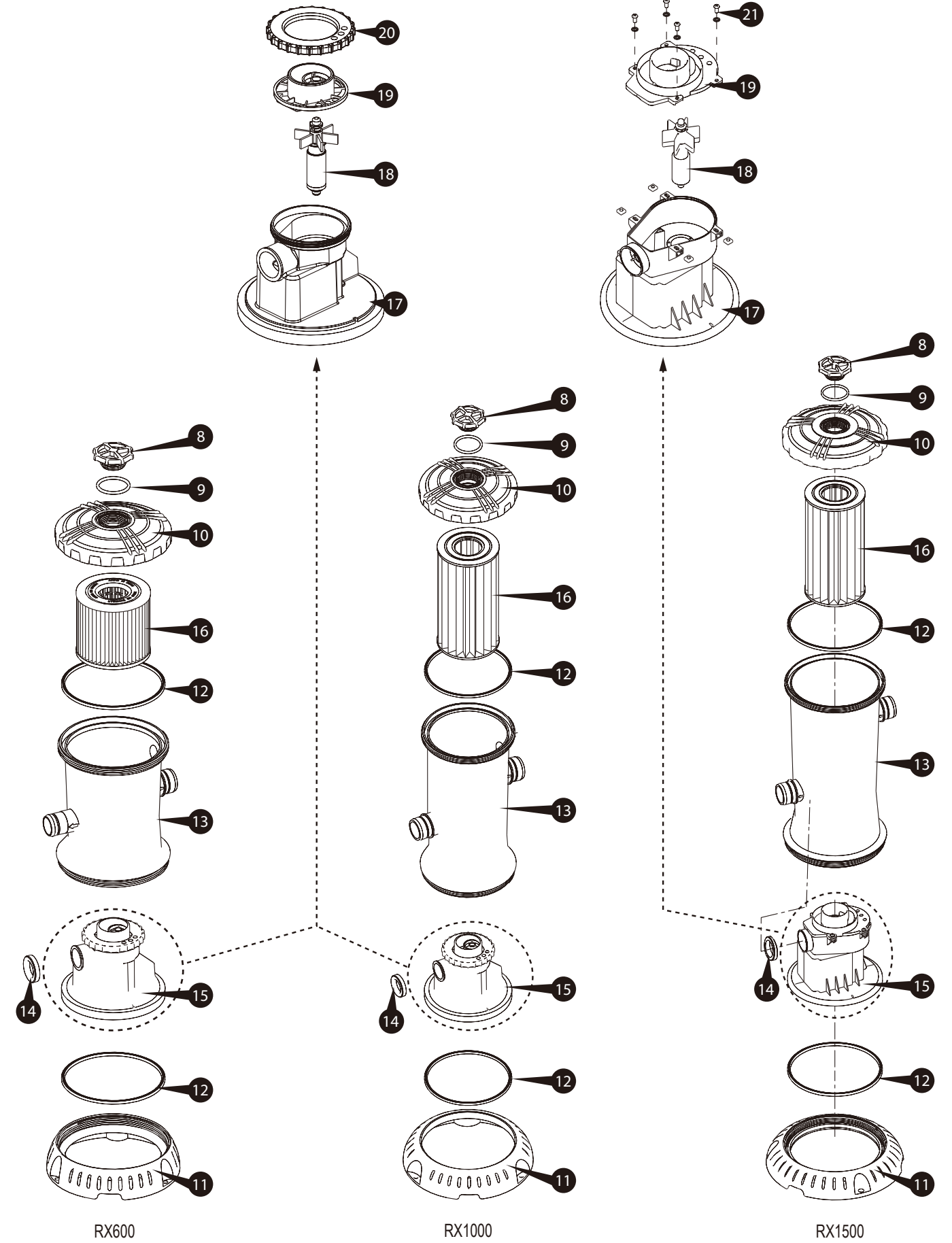
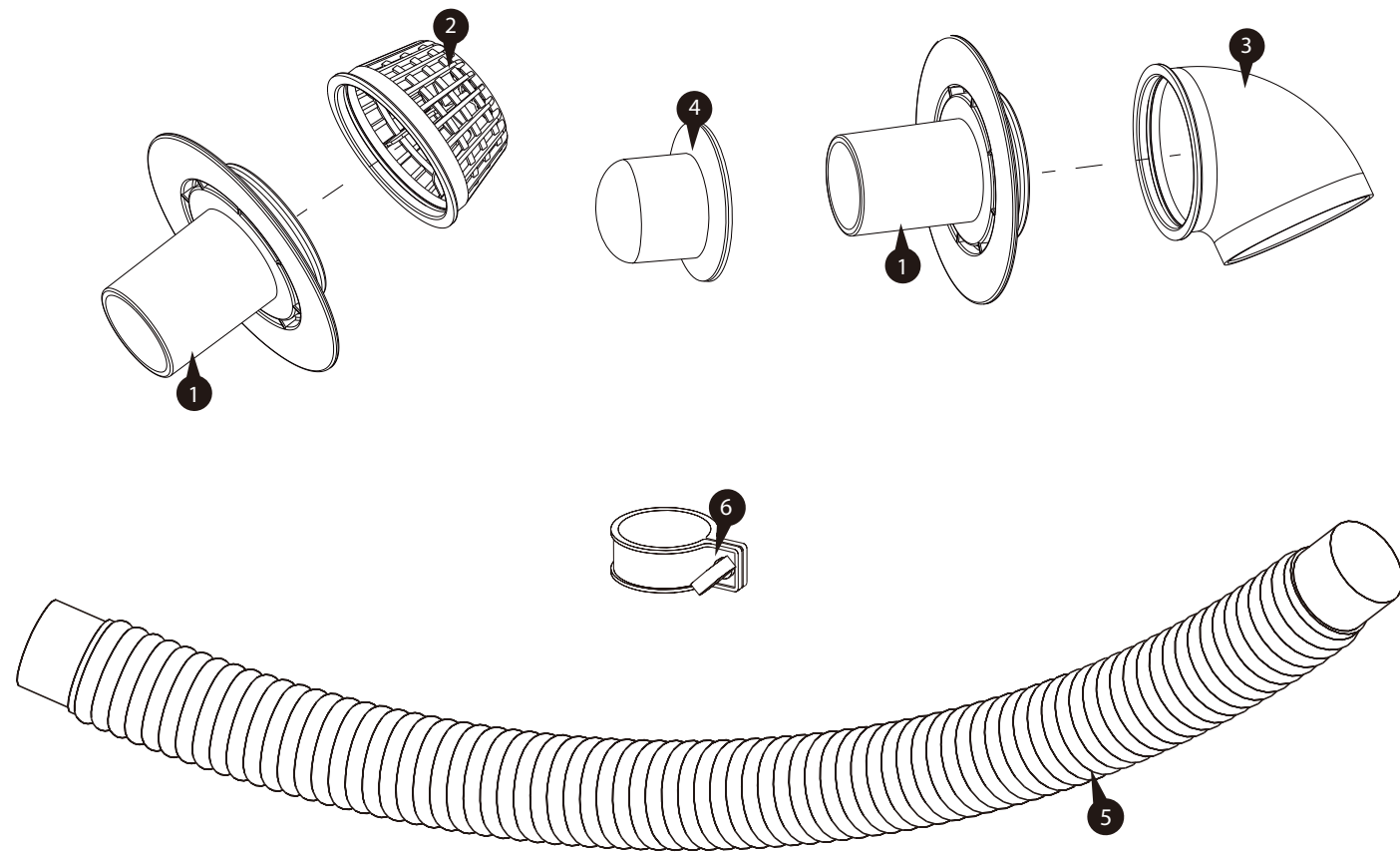
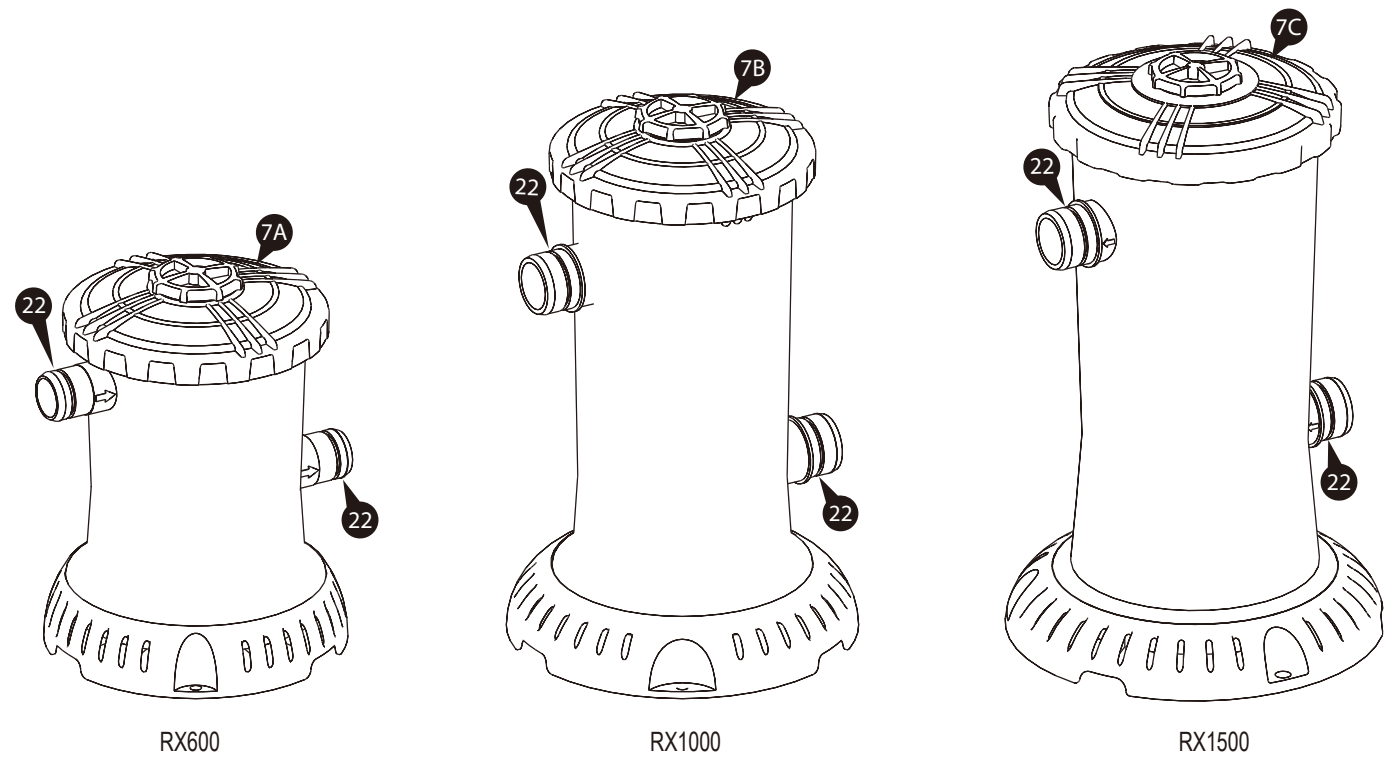

SETUP INSTRUCTIONS

Before assembling your product, please take a few minutes to check the contents and become familiar with all the parts.

⚠ WARNING: POSITION THIS PRODUCT AWAY FROM THE POOL, SO AS TO PREVENT CHILDREN FROM CLIMBING ON IT AND ACCESSING THE POOL.

- All electrical components must be installed in accordance with standard NFC 15-100.
- CAUTION: All filters comply with the installation standard NF EN C 15-100, stipulating that any electrical device situated less than 3.5 metres from the pool and which is freely accessible must run on low-voltage 12V power. Any electric device powered by 220V must be situated more than 2 metres from the edge of the pool. Contact the manufacturer regarding any modifications to one or more parts of the filter system.

1. Set up the pool by following all instructions that come with the pool. Do not fill water until the Filter Pump is properly installed. Locate the Outlet and Inlet openings on the pool wall.

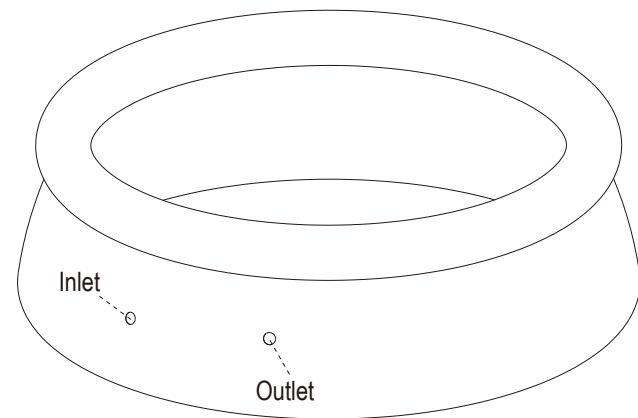

2. Install the Suction Fitting on the outlet opening of the pool.

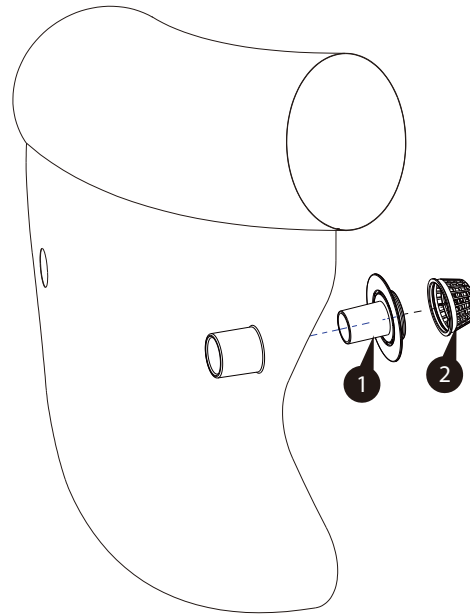

3. Install the return fitting on the Inlet opening of the pool.

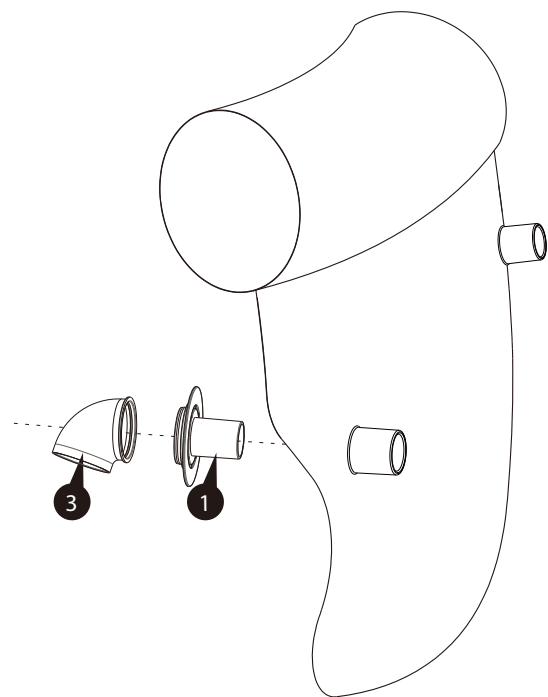

4. Remove the Filter Pump (7), Hoses (5), and Hose Clamps (6) from the package.

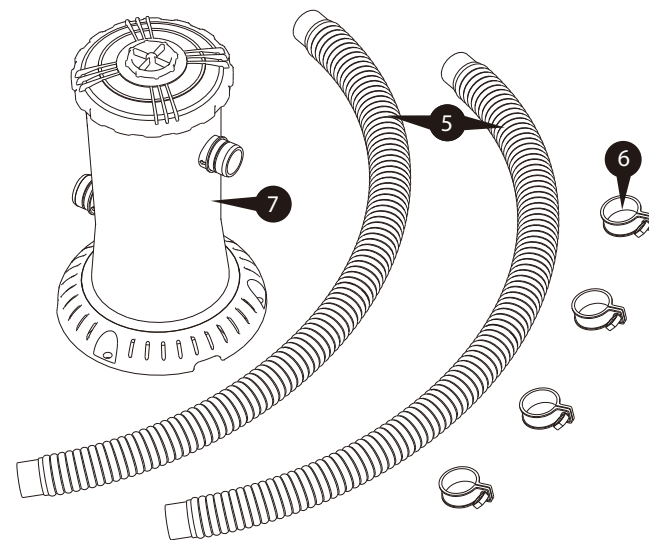

5. Connect the Hose (5) from the Suction Fitting (6) to the Filter Pump Inlet.

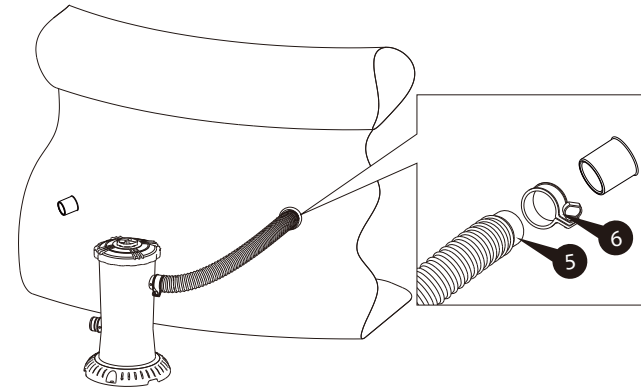

6. Connect the Hose (5) from the pool Return Fitting to the Filter Pump outlet.

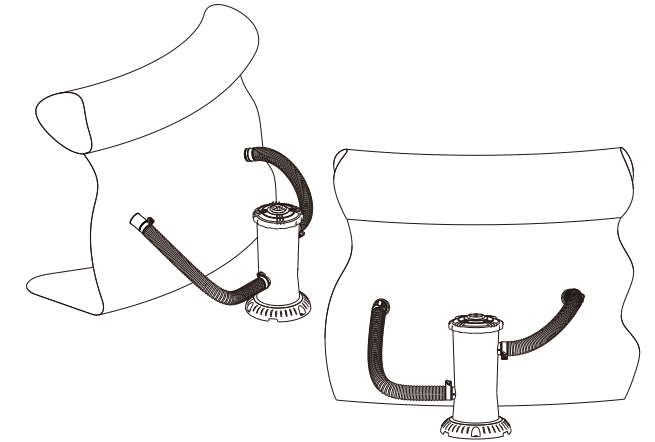

7. Tighten all Hose Clamps (6) to prevent water leakage.

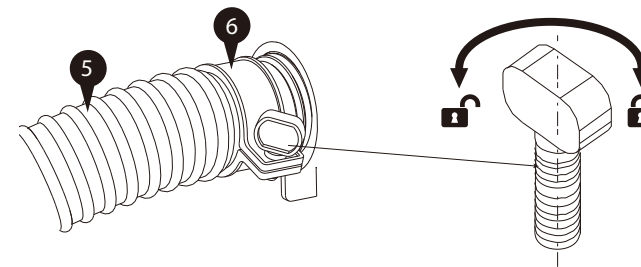

8. Do not plug in the filter pump at this point. Begin to fill water until the water level reaches the fill line.

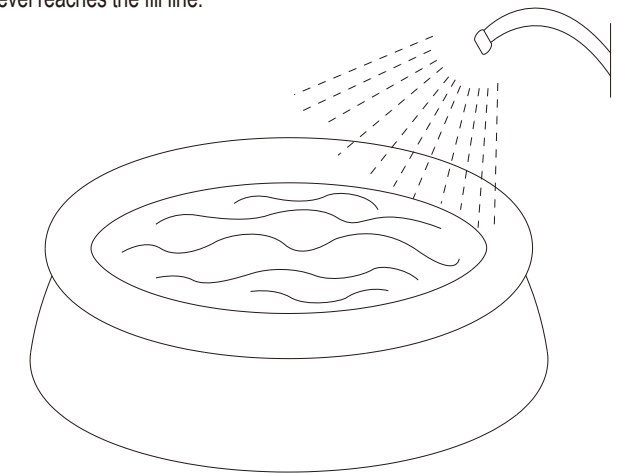

9. Air is now trapped inside the Filter Pump system, which will prevent the water from flowing smoothly. To VENT the system (release the trapped air), open the Vent Screw (8) at the top of the pump by turning it counter-clockwise. The water pressure will force out all the trapped air inside the Filter Pump system. Tighten the Vent Screw (8) when you see water flowing out from the Seal Top (10).

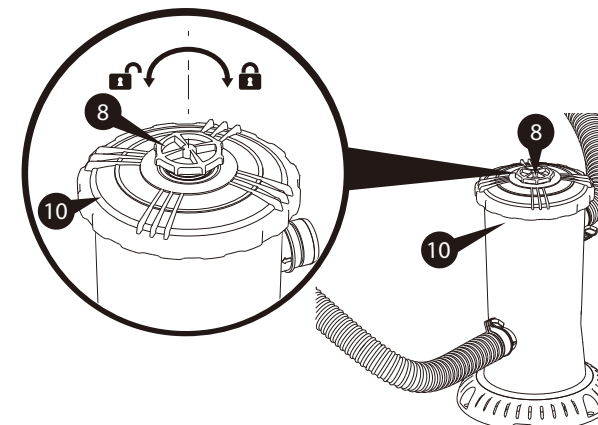

10. Adjust the Flow Diverter (3) to maximize the circulation of the pool water.

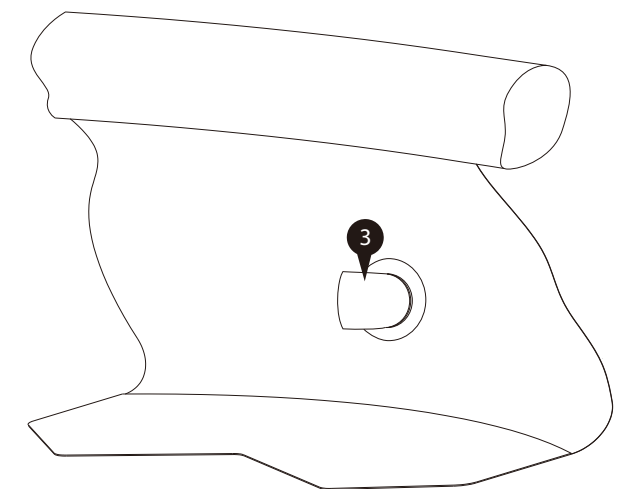

FILTER PUMP OPERATION

1. Check the return fitting on the inside of the pool for correct flow; it should feel like a solid stream of water returning to the pool. You can use the return flow as a gauge to determine when the filter needs cleaning or replacement. If you feel a reduction in flow, clean or replace filter.
2. Test water and adjust as needed, read - "PUMP WATER CARE". VERY IMPORTANT- FILTER PUMP ALONE WILL NOT PREVENT ALGAE FROM GROWING IN POOL WATER; THIS CAN ONLY BE DONE BY MAINTAINING PROPER CHLORINE AND pH LEVELS AT ALL TIMES!
3. The filter cartridge may need to be cleaned and/or replaced several times at start up until the correct chlorine and pH levels are attained. We recommend that you keep at least one spare filter cartridge on hand at all times. Filter cartridges may be purchased at the store you purchased your pool from, or ordered from Polygroup®.
4. To turn off the filter pump, unplug the power cord.
5. IMPORTANT: THE FILTER CARTRIDGE MUST BE FIRMLY SEATED OVER THE PUMP INTAKE PORT IN ORDER TO FILTER THE POOL EFFECTIVELY.
6. THE PUMP AND FILTER ALONE WILL NOT PREVENT ALGAE FROM APPEARING AND GROWING IN THE POOL; THIS CAN ONLY BE PREVENTED BY MAINTAINING PROPER CHLORINE AND pH LEVELS AT ALL TIMES!

PUMP MOTOR PROTECTION

IMPORTANT! Your filter pump is protected by a thermal switch. The switch senses the temperature of the filter pump. If it gets too hot, the switch will stop the pump from running until it cools off. It will automatically turn back on when the filter pump has cooled down. This is a safety device to prevent pump damage and prolong service life. If your pump is automatically turning off, it is because of high pool water temperature and/or low water flow through the pump. If this happens you need to check the water flow and correct it if needed, as this filter pump uses the water flow for cooling. You may also want to run the pump at night when the temperature is lower.

FILTER CARTRIDGE CLEANING AND REPLACEMENT

1. Unplug the Power Filter Pump. Remove the Flow Diverter ③, Suction Fitting Screen ② and Suction Fitting Base ① from the Return Fitting and Suction Fitting and flow plug with Plug ④.

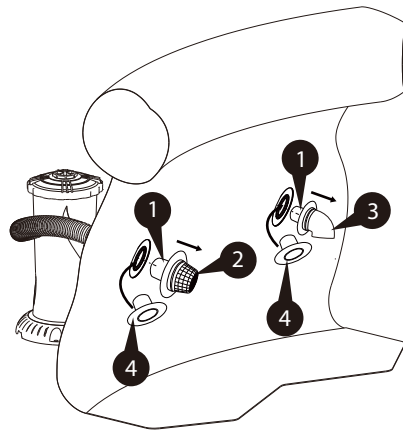

3. Use both hands to twist off the Seal Top ⑩ by turning counter-clockwise. Remove the Filter Cartridge ⑫.

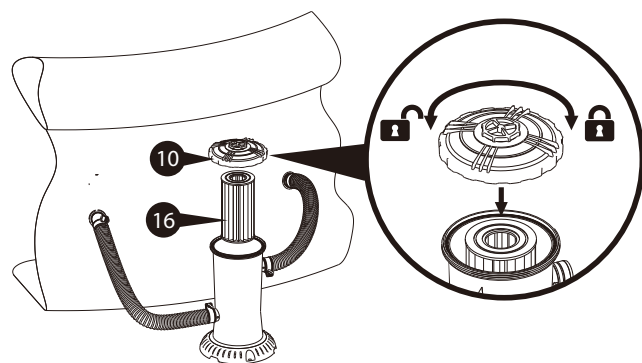

2. To depressurize the Filter Pump system, vent the filter pump by twisting the Vent Screw ⑧ counter-clockwise.

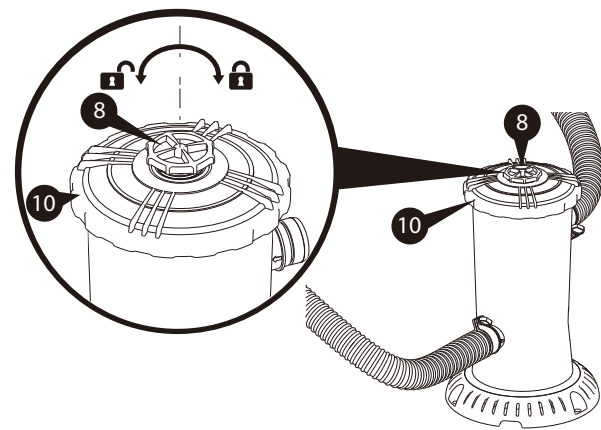

4. After you are finished cleaning the filter cartridge, liberally lubricate the GASKET ⑫ with petroleum jelly and re-assemble in reverse order. Before restarting the filter pump, be sure to remove the PLUG ④.

5. The filter cartridge can be cleansed of coarse dirt and debris by pressure washing inside and out with a garden hose, making sure to wash between all pleats. Fine particles of dirt are more easily removed from the filter pleats when the cartridge is dry. Therefore, after hosing the cartridge, allow the filter to dry and carefully brush, but do not scrub the pleated surface areas. Cleaning and scrubbing a filter too vigorously will also wear out the cartridge much faster than if it is simply hosed off correctly.

6. Suntan oils, body oils, and algae can form a coating on the filter pleats which may not be thoroughly removed by hosing. Such films of oils and/or algae will rapidly clog up the filters' pores, greatly reducing filtration. Therefore, it is imperative to remove such materials from the filter element as soon as possible. To remove oils, we recommend soaking the cartridge in a solution of 1 pound of tri-sodium phosphate (or any other strong detergent) to 5 gallons of water for up to 12 hours. Tri-sodium phosphate is available in many supermarkets, hardware stores, or janitorial supply stores. After the oils have been removed, rinse the filter cartridge to remove any dirt. If algae is a problem, add 1/2 pint of pool chlorine or 1 pint of liquid household bleach to the cleaning solution, 1 hour before removing the filter cartridge from the solution. Thoroughly rinse the filter cartridge before replacing it in the filter case. Check the pool chemistry to determine the cause of algae growth.
7. Excessive calcium and/or mineral deposits may build up on a filter cartridge and should be handled differently. Contact your local pool supply store to ask about additional filter cartridge cleaners or treatment for calcium or mineral deposits. Check pool chemistry for high pH or alkalinity; this may cause a calcium or mineral build-up.
8. A spare "stand-by" Filter Cartridge ⑫ is an excellent investment. It provides a convenient way to continue filtration of your pool while cleaning or replacing a dirty Filter Cartridge ⑫. Also, a well-maintained, clean cartridge assures you that your filter will always be ready to operate at peak efficiency.
9. Filter cartridges may be purchased at the store you purchased your pool from, or ordered from Polygroup®. Always replace with genuine Polygroup® SUMMER WAVES™ filter cartridges.

PUMP MAINTENANCE

1. Check and adjust pH and chlorine levels daily using required chemicals. See Section "PUMP WATER CARE."
2. Check filter pump output daily. If flow is reduced, see Symptom 2 in Section "TROUBLE SHOOTING GUIDE."
3. Check filter pump, hoses, fitting for leaks. If a leak is found, see Symptom 4 in Section "TROUBLE SHOOTING GUIDE."
4. It is essential to change any damaged element or set of elements as soon as possible. Use only parts approved by the person responsible for placing the product on the market.
5. All filters and filter media shall be inspected regularly to ensure that there is not a build-up of detritus thus preventing good filtration. The disposal of any used filter media should also be in accordance with applicable regulations/legislation.
6. Check the filter for leaks. If you find a leak, refer to Symptom 4 in the section "TROUBLESHOOTING GUIDE".
7. During the season in which the pool is in use, the filter system must be operated each day for a sufficient period of time to ensure that the volume of water in the pool is completely renewed at least once.

PUMP WATER CARE

1. The following items are required and readily available from your local pump supply store:
 - TEST KIT - Used to check chlorine and pH levels.
 - 1-inch[2.54cm] CHLORINE TABLETS - Used to disinfect pump water and help control the growth of algae.
 - pH CONTROL CHEMICALS - Used to adjust pH levels Up (Soda Ash) or Down (Acid).
 - ALGAECIDES - Used to eliminate algae.
 - SUPERCHLORINATOR - Used to destroy combined chlorine, ammonia, nitrogen, and organic compounds.
 - LEAF NET with handle - Used to remove leaves, trash, insects, etc. from pump.
 - CHLORINE DISPENSER (Supplied with Polygroup®'s patented Filter Cartridge U.S. Pat. 7,005,062) - Used to dispense 1-inch[2.54cm] chlorine tablets ONLY.

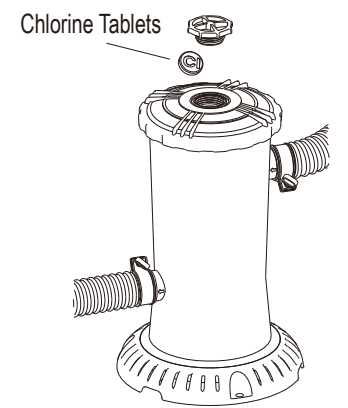

2. Use test kit daily to check pH and chlorine levels. Adjust accordingly using the required chemicals.
- NOTE :** Excessive levels of chlorine or low pH levels will damage pool liner.
3. The pump can be cleaned using a garden hose powered vacuum from Polygroup® or a pump supply store.
4. Using a foot bath near the pump to wash off your feet prior to entering the pool will assist in keeping the pool clean.
5. Well water often presents special problems with water chemistry. If you must use well water, take a sample to your local pump chemical supplier for analysis before adding ANY chemicals.
6. Refer to the POOL's USER MANUEL for the capacity of your pool. You will need this information to determine the amount of chemicals you will need to correct the pump water. **NOTE:** It is recommended to use a 5 gallon bucket of water to mix and dissolve your chemicals and then applying directly to the pool water. Follow manufacturers label directions on all chemicals.*Most pool supply stores will test your pump water for free and advise you of what chemicals you need, and the correct amount to use for your pump. You will need to tell them the pump capacity in gallons.
7. **IMPORTANT -** We cannot over-stress the importance of proper and adequate daily chemical treatment. Chlorine and pH levels must be properly maintained at all times. **PUMP AND FILTER ALONE WILL NOT PREVENT ALGAE FROM GROWING IN POOL WATER; THIS CAN ONLY BE DONE BY MAINTAINING PROPER CHLORINE AND pH LEVELS AT ALL TIMES.**
 - Maintain pH level between 7.3 and 7.8.
 - Maintain chlorine level between 1.0 and 1.6 ppm (parts per million).
 - Super chlorinate your pump at least every other week.

NOTE :

1. Hot weather/heavy use may require pH and chlorine levels to be maintained on the upper side of the scale and superchlorination of the pool every week.
2. Using a pool cover and/or solar cover will assist in maintaining your pH and chlorine levels by reducing the amount of evaporation from your pool.

CAUTION - Concentrated chlorine levels and low pH levels will damage pool. You must follow the instructions for the pool chemicals you use, as to quantity and recommended usage. NEVER drop lumps or pellets of chemicals in pool; this may present a hazard to swimmers and/or damage your liner.

TROUBLESHOOTING GUIDE

⚠ WARNING: UNPLUG THE POWER CORD BEFORE TROUBLESHOOTING THE FILTER PUMP.

SYMPTOM	CAUSE	SOLUTION
1 Motor fails to start or kicks on and off	A Pump transformer not plugged in	A Pump transformer must be plugged into a grounded power outlet.
	B Low voltage	B Check the line voltage, it must be in the range of 215V to 245V (See product label).
2 No or slow water flow through the return fitting.	A Low pool water level	A Fill the pool to the fill line. The suction fitting must be at least 4" under water.
	B Inlet/Outlet clogged	B Check for obstruction(s) at the suction fitting and return fitting.
	C Dirty filter cartridge	C Clean or replace the filter cartridge. A spare cartridge makes service more convenient.
3 Filter pump is not cleaning the pool properly (Cloudy water, green.....etc.)	A Chlorine level	A Maintain chlorine level between 1.0 to 1.6 ppm.
	B pH level	B Maintain pH level between 7.3 to 7.8.
	C Dirty filter cartridge	C Clean or replace the filter cartridge.
	D Damaged filter cartridge	D Check filter for damage and holes. Replace new filter immediately.
	E Slow water flow	E Check for obstruction(s) at the suction fitting and return fitting.
	F Other chemicals required	F Have the pool water sample tested by a pool supply store. Obtain opinions on additional water treatment chemicals.
	G Pool water very dirty	G Run pump more often, but never when the pump is in use. Clean/replace filter cartridge more frequently.
4 Water leakage	A Suction/return hose	A Tighten the hose clamps. Check the o-rings on the suction/return fittings. Check hoses for damage. Replace if needed.
	B Vent screw in Seal Top	B Check O-ring 9 for damage. Replace if needed. Tighten the Vent Screw 8.
	C Seal Top	C Check O-ring 12 for damage. Replace if needed. Tighten the Seal Top 10.
	D Baes	D Check O-ring 12 for damage. Replace if needed. Tighten the Base 11.

POOL PUMP DISASSEMBLY & STORAGE

1. Unplug the Power Filter Pump. Remove the Flow Diverter 3, Suction Fitting Screen 2 and Suction Fitting Base 1 from the Return Fitting and Suction Fitting and flow plug with Plug 4.
2. Slowly unscrew the Vent Screw 8 from the Seal Top 10 allowing the Filter Pump to depressurize.
3. Remove the Seal Top 10 by turning counter-clockwise.
4. Remove the Filter Cartridge 16 and remove any chlorine tablets left inside the core section of the filter.
5. Loosen all four Hose Clamps 6, remove the Hoses 5 and allow water to drain out.
6. Clean and dry all filter pump parts including filter cartridges.
7. Liberally lubricate the O-rings 9 at the Seal Top 10 and Gasket 12 on the Canister 13 with petroleum jelly, and then reassemble it along with the Seal Top 10, Vent Screw 8 onto the Canister 13. Store all parts carefully. In a airtight plastic bag.

ROTOR REPLACEMENT INSTRUCTION

1. Unplug the Power Filter Pump. Remove the Flow Diverter 3, Suction Fitting Screen 2 and Suction Fitting Base 1 from the Return Fitting and Suction Fitting and flow plug with Plug 4.
2. To depressurize the Filter Pump system, vent the filter pump by twisting the Vent Screw 8 counter-clockwise.
3. Loosen the Hose Clamps 6 at the filter pump inlet and outlet. Detach both Hoses 5 from the filter pump.
4. Turn the filter pump up-side-down. The Base 11 is now locked by a latch pin. To release the lock, push the latch pin down and then turn left. Detach the Base 11 from the Canister 13 by turning counter-clockwise.

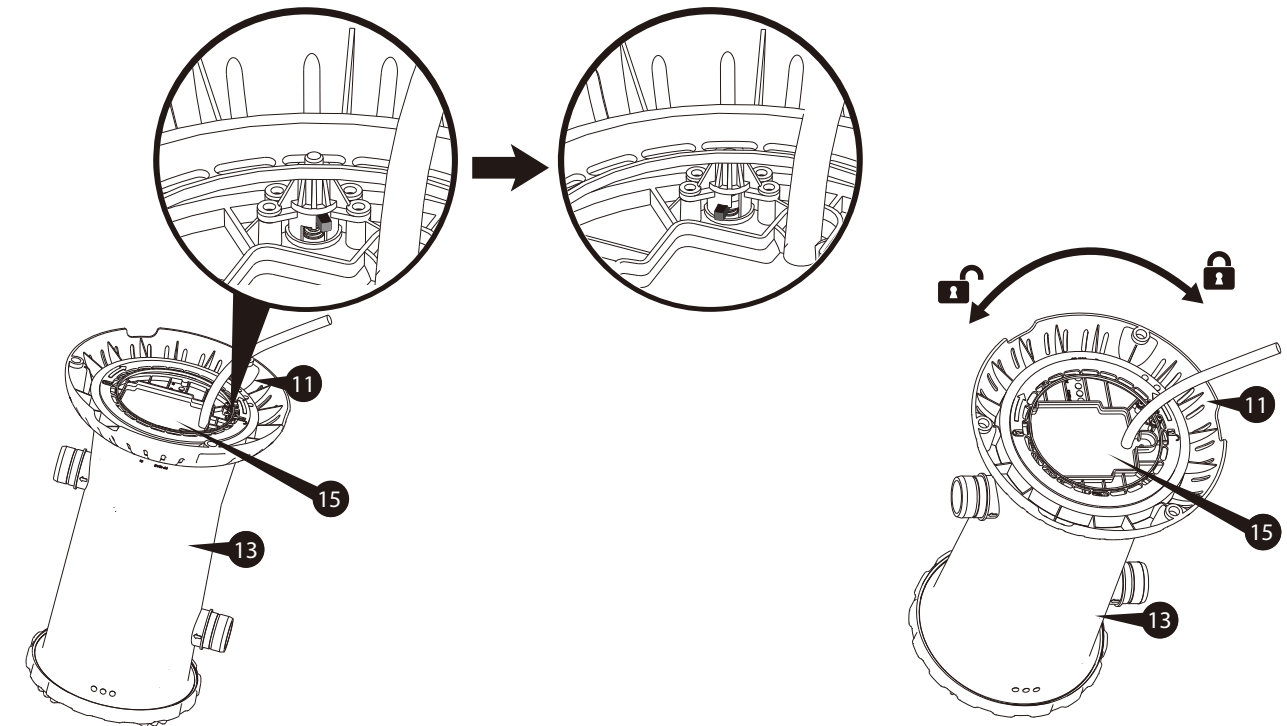

5. Remove the Base 11 from the Canister 13.

6. Remove the Motor Assembly 15 from the Canister 13. Be careful not to lose the rubber Nozzle 14.

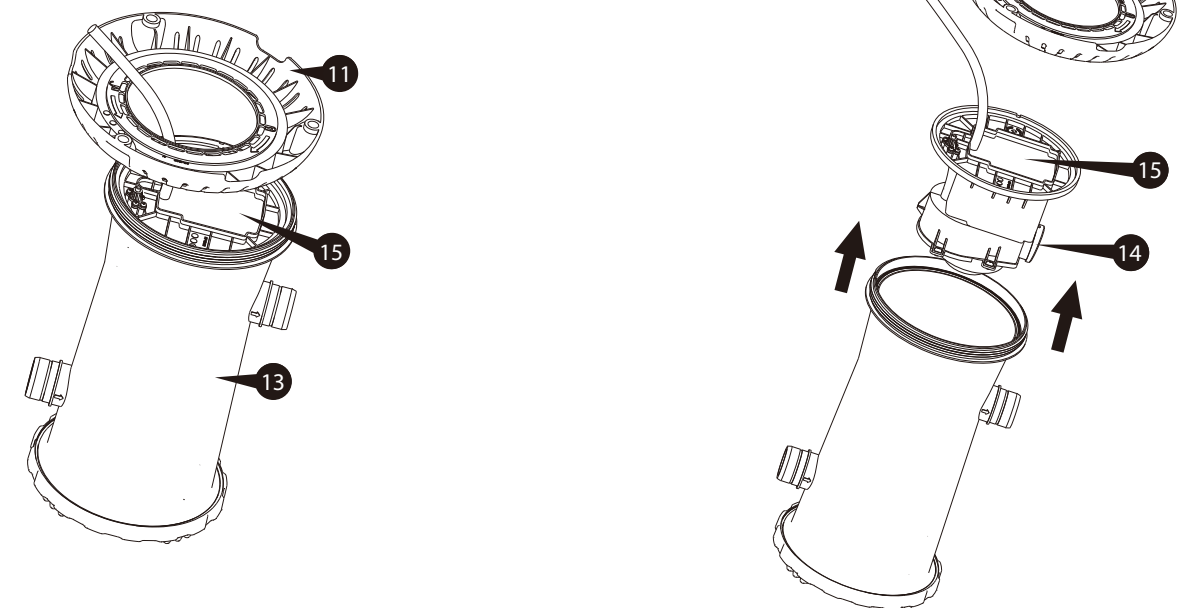

7. To replace the Rotor Assembly 18, remove the Volute Cover 19 and pull out the Rotor Assembly 18 from the Stator 17. Insert new Rotor Assembly 18 into the Stator 17.

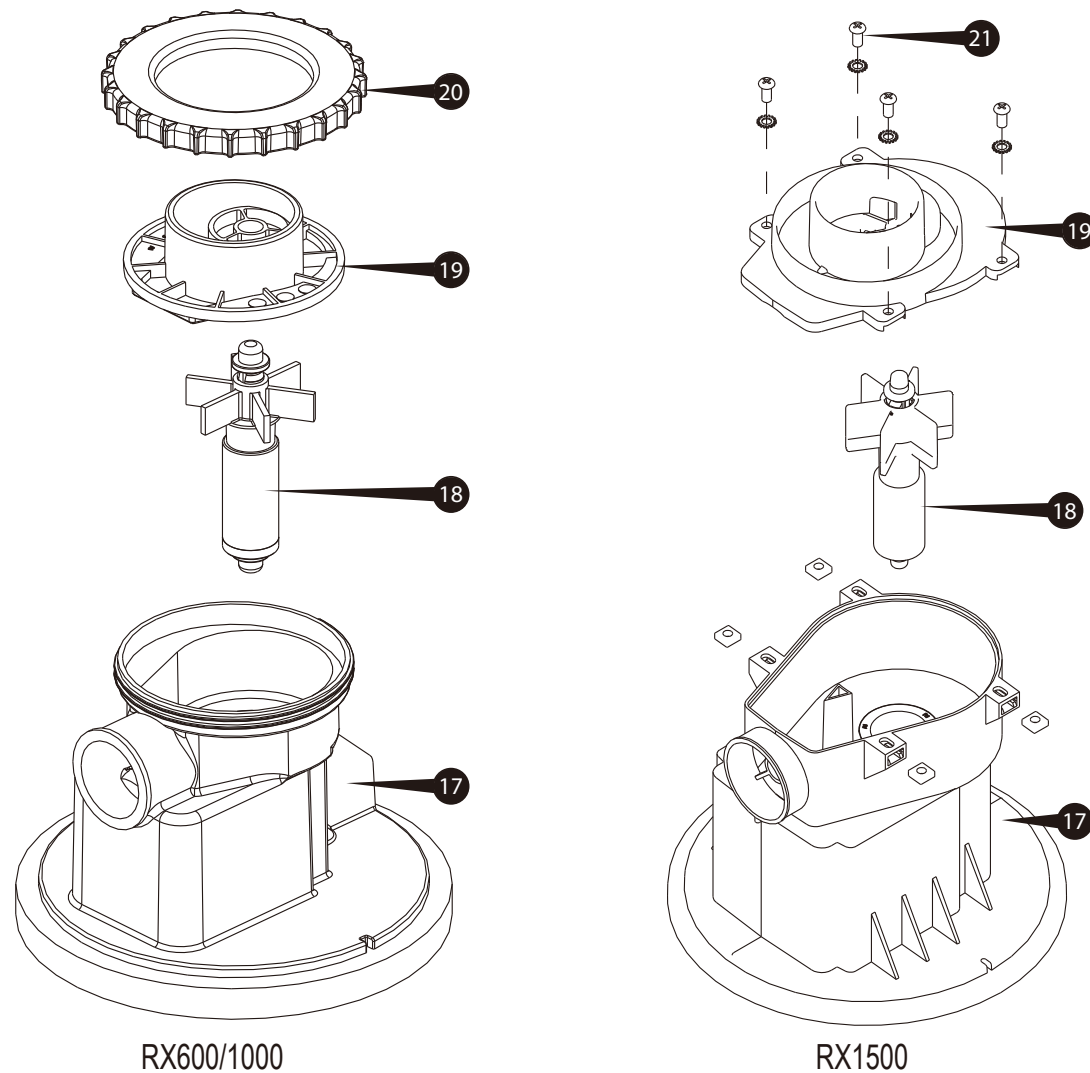

RX600/1000

RX1500

8. Align the Shaft properly and fasten the Volute cover 19 with the Volute Cover Lock Nut 20 or with the Volute Cover Bolt and Nut Set 21.
9. Attach the Nozzle 14 to the outlet of Motor Assembly.
10. Slowly insert the motor assembly 15 back into the Canister 13, so that the Nozzle 14 is aligned with the outlet port of the Canister 13.
11. Tighten the Base 11 by turning clockwise, be sure the Gasket 12 is properly in place. To lock the Base 11, apply the latch pin by turning to the right.

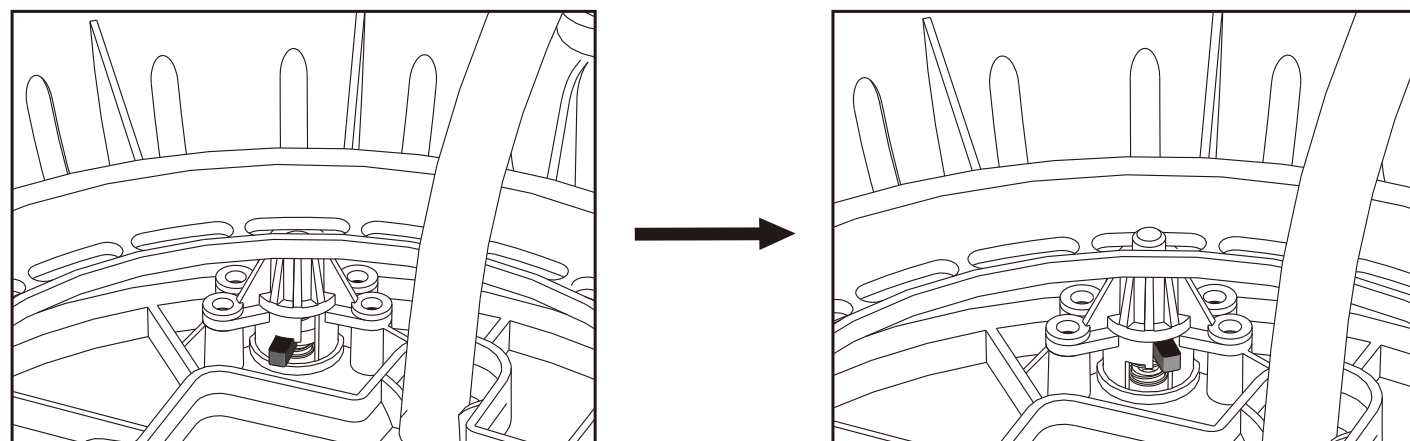

REPLACEMENT PARTS ORDERING INFORMATION

KEY	DESCRIPTION	RX600	RX1000	RX1500
		PART #		
1	Suction Fitting Base	P58PF2820P01	P58PF2820P01	P58PF2820P01
2	Suction Fitting Screen	P58PF7800W05	P58PF7780W05	P58PF7780W05
3	Flow Diverter	P58PF7790W05	P58PF7790W05	P58PF7790W05
4	Plug	P58PF0620K01	P58PF0620K01	P58PF0620K01
5	Hose	P58125036W01	P58150036W01	P58150036W01
6	Hose Clamp	P58220221W05	P58219221W05	P58219221W05
8	Vent Screw	P58182201W05	P58182201W05	P58182201W05
9	Vent Screw O-Ring	P58182501K01	P58182501K01	P58182501K01
10	Seal Top	P58PF1007W05	P58PF1007W05	P58PP1853W05
11	Base	P58100740W05	P58PF1013W05	P58183901W05
12	Canister Gasket	P58147800K01	P58147800K01	P58164800K01
13	Filter Pump Canister	P5810030AW05	P58PF1006W05	P58PP1840W05
14	Nozzle	P58182601K01	P58182601K01	P58185201K01
15	Motor Assembly	P58X600CGS00	P58X1000GS00	P58X1500GS00
	Motor Assembly(UK)	P58X600CBS00	P58X1000BS00	P58X1500BS00
16	Type D Filter Cartridge	P583041037PR		
	Type A/C Filter Cartridge		P583041080PR	P583041080PR
18	Rotor Assembly	P58050137001	P58050505001	P58050506001
19	Volute Cover	P58PF1009K01	P58PF1009E09	P58184501K01
20	Volute Cover Lock Nut (X-600 & X-1000)	P58PF1010K01	P58PF1010K01	
21	Volute Cover Bolt and Nut Set (X-1500 only)			P5800400080A
22	Filter Pump Port / Fitting O-Ring	P58030001K01	P58037000K01	P58037000K01
24	102" Hose	P584125002W1	P584150004W1	P584150004W1

* For RX Series Filter Pump sold separately

PUMP STORAGE & WINTERIZING

Winterizing Your Pump and Long-term Storage

After usage, you can easily empty and store away your pump in a safe place. Some pump owners, however, choose to leave their pump up all year round. In cold areas, where freezing temperatures occur, there can be a risk of ice damage to your pump. We therefore recommend you drain, disassemble, and properly store the pump, when the temperature drops below 32 degrees Fahrenheit (0 degrees Celsius).

Clean the Pump Water Thoroughly

1. Let the pump cool down for at least 30 minutes before storage. Clean the pump water thoroughly.
2. Use only damp cloth soaked in mild soap / detergent and water to clean the outer surfaces of the pump. Do not use any kind of chemical or solvent. Always unplug the pump and stow the cord during cleaning.
3. Keep out of reach of direct sunlight and chemical substances.
4. Save the original packing box for storage purposes.
5. Remove the pipes (if applicable) and store in a safe place. Be sure all accessories parts are clean and completely dry before storage.
6. Bring pump and accessories indoors and store in a safe and dry area, preferably between 32 degrees Fahrenheit (0 degrees Celsius) and 104 degrees Fahrenheit (40 degrees Celsius).